

Non-contact Line-laser Sensor SurfaceMeasure 1008S

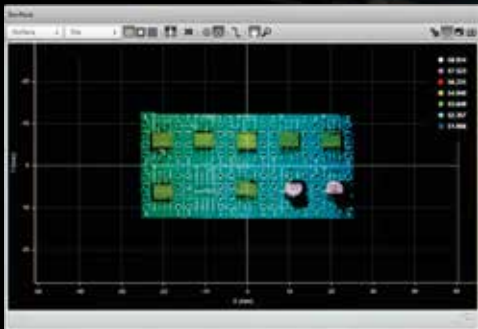

Line-laser sensor providing stable measurements with simple operations

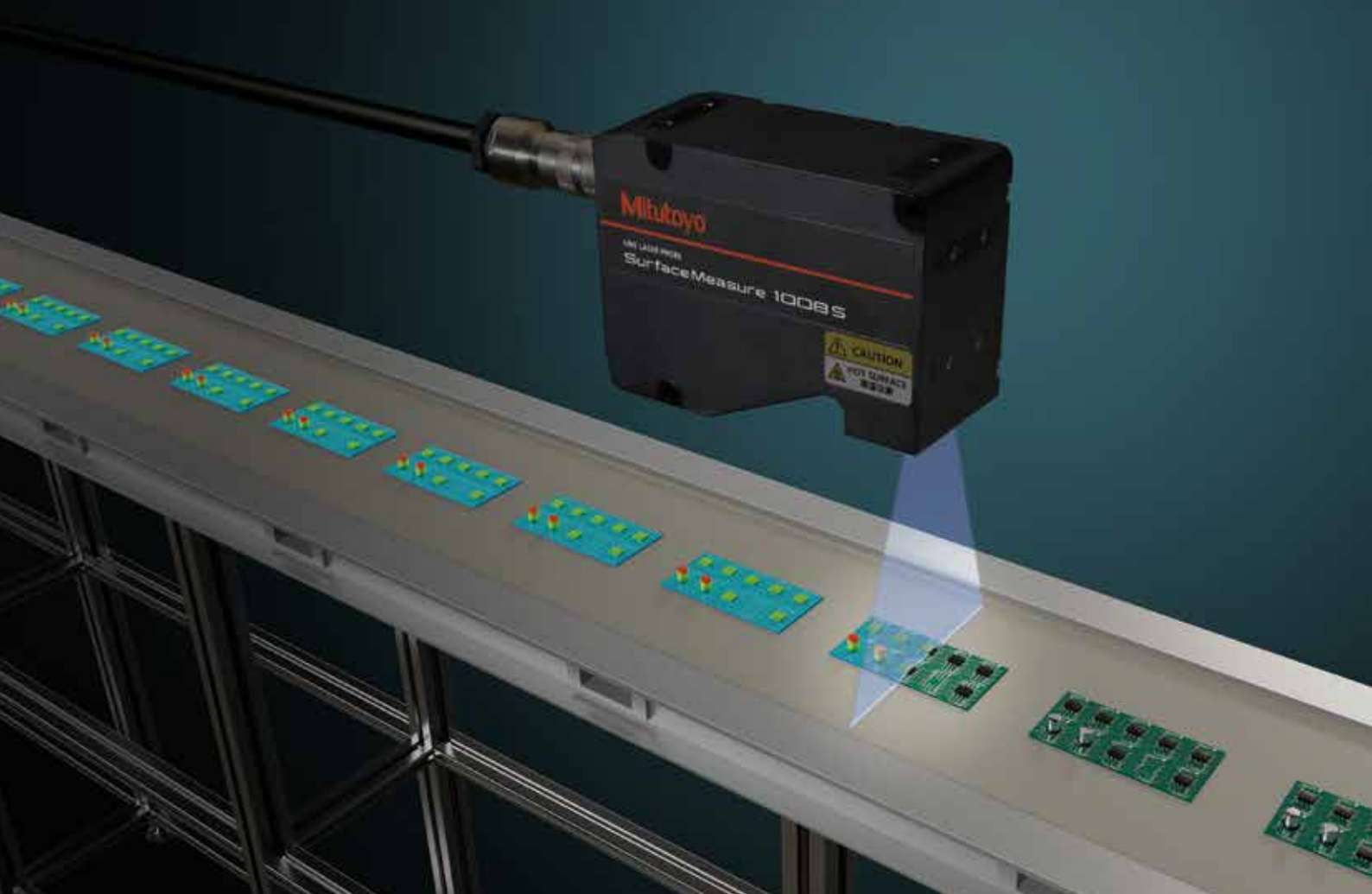

System configuration (example)

This is an example of the system configuration of SurfaceMeasure1008S. Various other system configurations are also available.

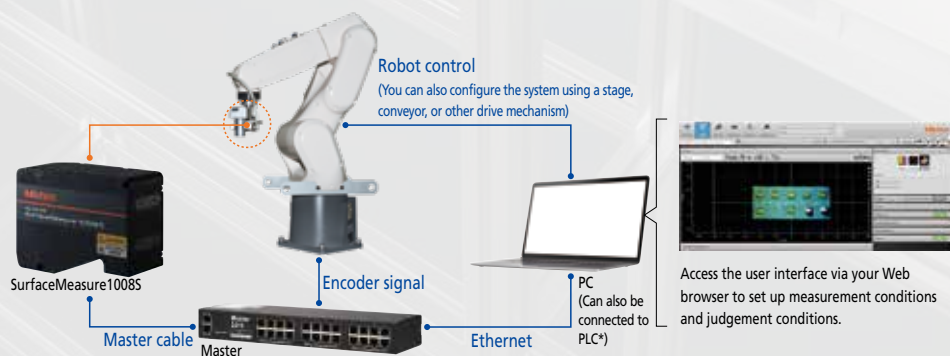

* PLC protocol: Modbus TCP, EtherNet/IP, PROFINET

Product structure

This line-laser sensor combines the optical technology and sensor technology of Mitutoyo.

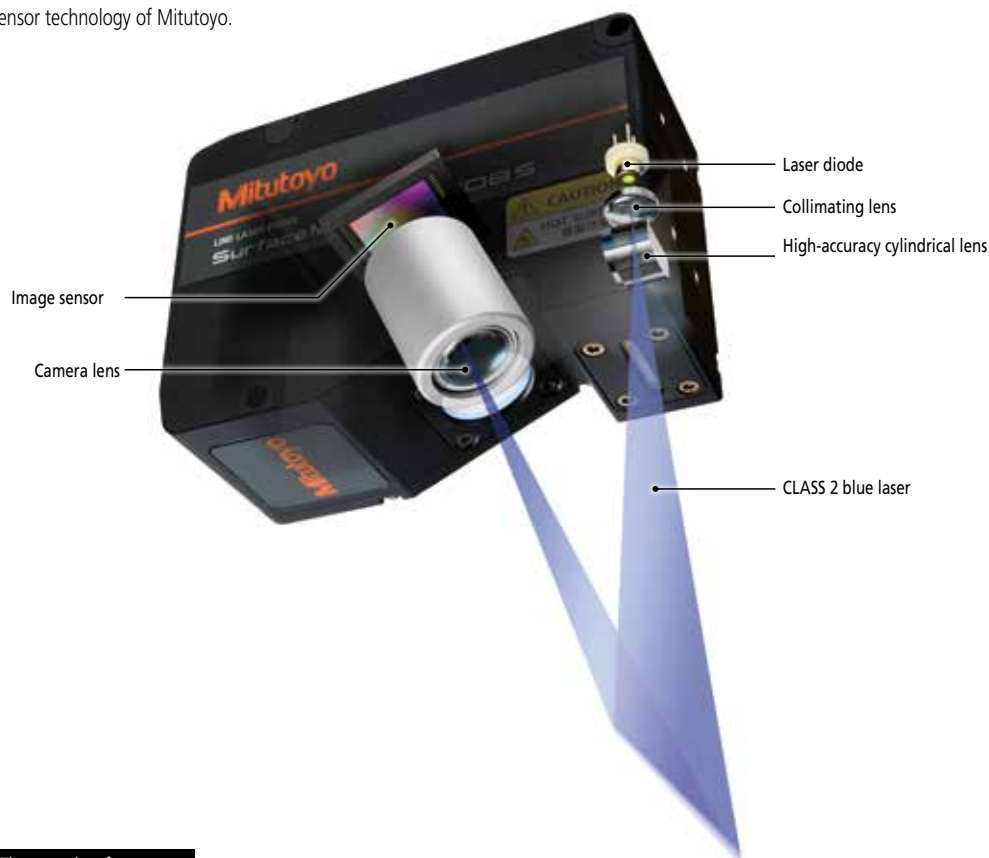

Three product features

— (1) High-accuracy and environment-resistant sensor

The sensor itself is guaranteed for an accuracy of 20 μm and a Z repeatability of 0.5 μm . It has also achieved the IP67 protection level, providing stable measurements.

— (2) Supporting automated measurement

The **SurfaceMeasure1008S** can obtain the profiles and three-dimensional shapes of measurement workpieces at high speed (a maximum frame rate of 10 kHz) and make an automatic judgement inside the sensor. It is also equipped with a parts matching function that allows the measurement tool to be applied throughout, regardless of the orientations of the parts being measured. Measurements can be taken without performing alignment.

— (3) Simple operability

The software supports intuitive operation and is built into the sensor (software installation is not required), so you can use it immediately after mounting.

APPLICATION

Automobile industry

Panel gap inspection

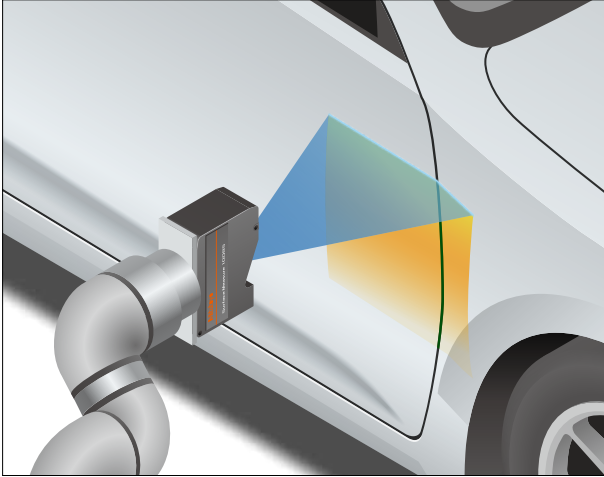

Rubber and tire industries

Tire shape inspection

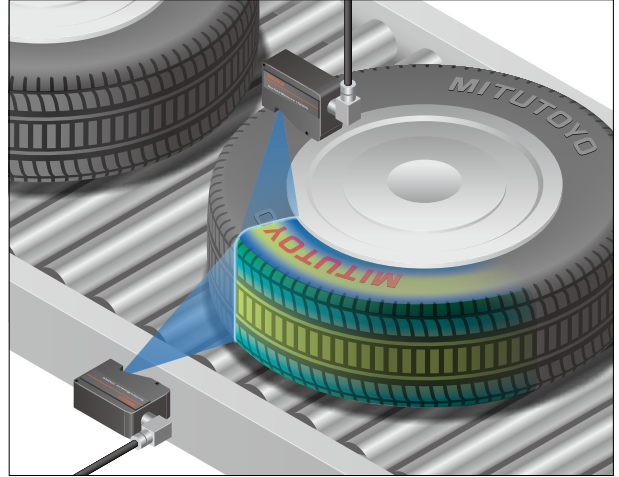

Electric vehicle battery industry

Cell assembly inspection

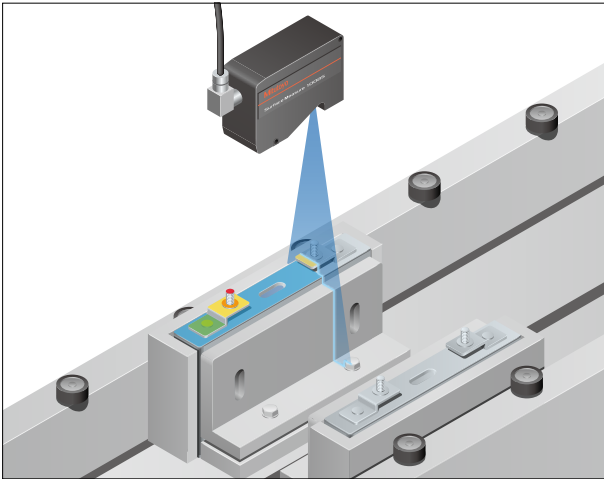

Electrical and electronic industries

Adhesive inspection

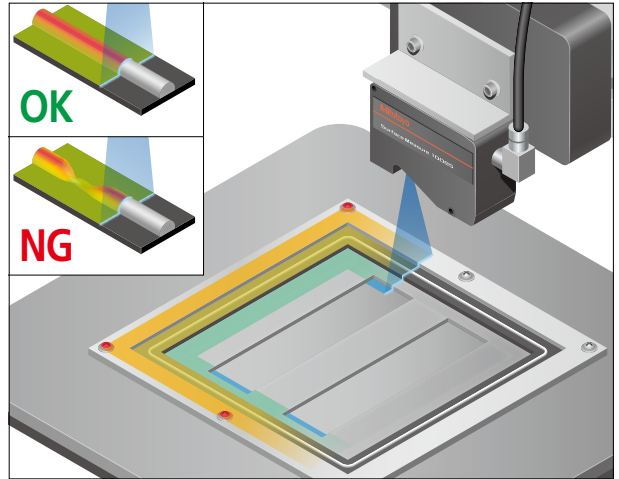

Electrical and electronic industries

Connector pin inspection

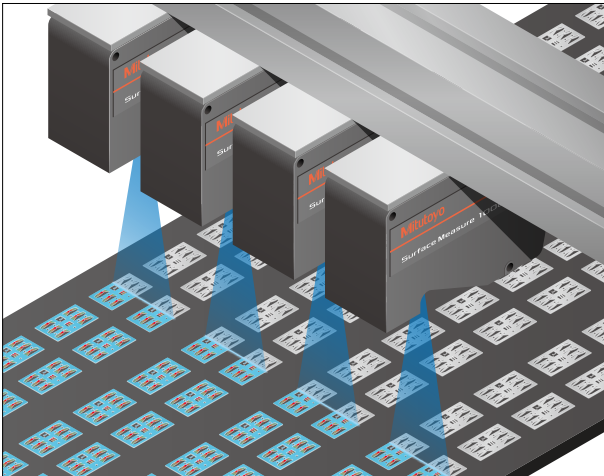

Food industry

Standard inspection of food, etc.

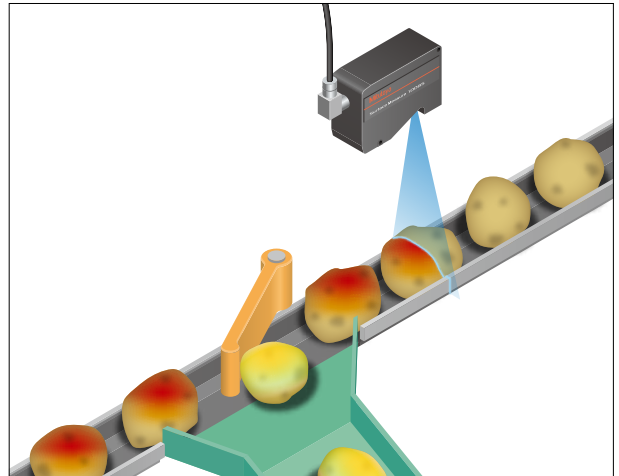

SOFTWARE

Powerful interface with excellent operability and functionality

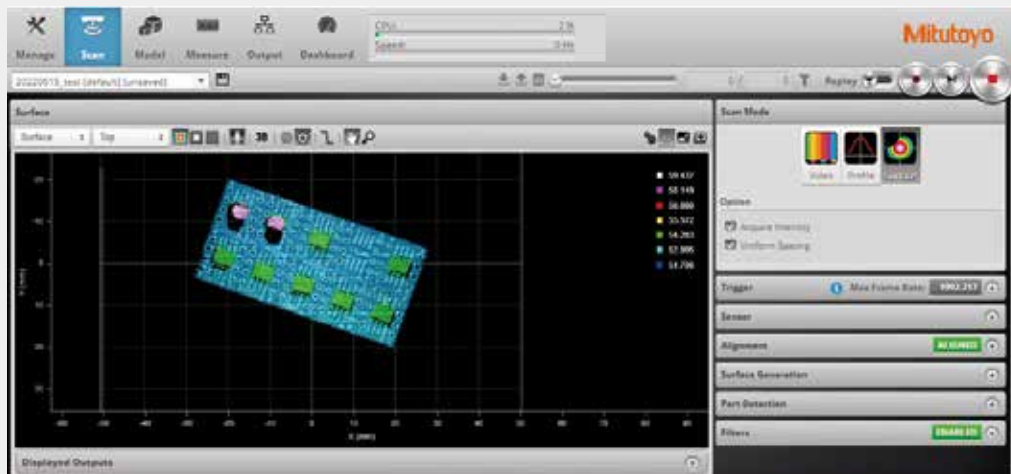

- Excellent operability simply by using a mouse
- Simple and intuitive interface
- Web browser-based, no need to install software
- Various built-in measurement tools
- 2D and 3D data can be obtained



Easy-to-configure measuring system

Measurement tool

- Pattern matching
- Countersink Hole
- OCR (Optical character recognition)
- Gap & Flush
- Groove
- Size

Various measurement tools such as these are available.



Pattern matching



Countersink Hole



OCR



Gap & Flush

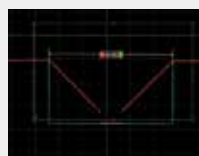

Groove



Size

Emulator

Using the emulator makes it possible to consider measurement conditions or make an analysis with obtained data even when offline.

SurfaceMeasure1008S

Specifications

Order No.	553-100	
Maximum measuring width	100 mm	
Measuring range	80 mm	
Working distance	80 mm	
Scanning error (1 σ) ^{*1}	20 μ m	
Frame rate	Max. 10 kHz	
Laser class	EN / IEC	CLASS 2 (EN / IEC 60825-1: 2014)
	JIS	CLASS 2 (JIS C 6802: 2014)
Line laser	Laser medium	Semiconductor laser
	Wavelength	405 nm (visible)
	Max. output	2.2 mW
Mass	650 g	
Operating environment	Temperature	0 °C to 40 °C
	Humidity	RH 20 to 80%, non-condensing
Storage environment	Temperature	-30 °C to 70 °C
	Humidity	RH 20 to 95%, non-condensing
IP code	IP 67 ^{*2}	
Power supply (power consumption)	24 to 48 VDC (15 W)	

*1 Accuracy inspection environment: Temperature 20 °C \pm 1 °C, Humidity 50%RH \pm 10%RH

Measurement workpieces: Specified reference ball for inspection (Φ 30 mm)

Inspection method: Determined by Mitutoyo-specified inspection method.

The operating environment and the storage environment are different from the guaranteed accuracy environment.

*2 Measuring accuracy may deteriorate if any water droplet or dust particle adheres to the optical path.

External dimensions

Unit: mm

• Measuring range

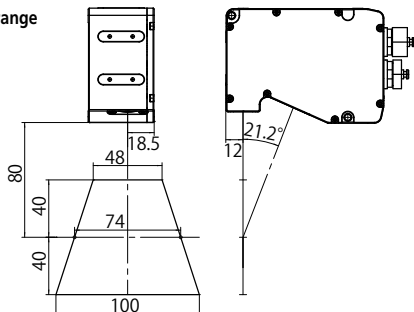

• Mounting size

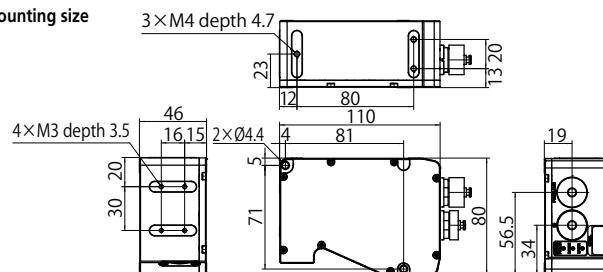

Sensor networking hub Master

In the multi-sensor system, this device is used for distributing power to sensors and synchronizing the sensors.

Input: Power supply 24 to 48 V, Laser Enable input, Encoder input, External input



Master2410

Order No.	Product Name	Remarks
02AQL401	Master810	Accepting a maximum of 8 sensors
02AQL402	Master2410	Accepting a maximum of 24 sensors

Master cable

Cable for the connection between sensor and Master.



Specifications	Sensor side	M16 connector (Straight or 90° upward-pointing can be selected)
	Power supply side	RJ45 (Connect to Master)
	Communication side	RJ45 (Ethernet connection)

Order No.	Product Name	Remarks
02AQL373	2 m Power and Ethernet Master	2×RJ45 ends
02AQL374	5 m Power and Ethernet Master	2×RJ45 ends
02AQL375	10 m Power and Ethernet Master	2×RJ45 ends
02AQL376	15 m Power and Ethernet Master	2×RJ45 ends
02AQL377	20 m Power and Ethernet Master	2×RJ45 ends
02AQL378	25 m Power and Ethernet Master	2×RJ45 ends
02AQL391	2 m Power and Ethernet Master 90deg	2×RJ45 ends, 90° connector
02AQL392	5 m Power and Ethernet Master 90deg	2×RJ45 ends, 90° connector
02AQL393	10 m Power and Ethernet Master 90deg	2×RJ45 ends, 90° connector
02AQL394	15 m Power and Ethernet Master 90deg	2×RJ45 ends, 90° connector
02AQL395	20 m Power and Ethernet Master 90deg	2×RJ45 ends, 90° connector
02AQL396	25 m Power and Ethernet Master 90deg	2×RJ45 ends, 90° connector

Power and Ethernet cable

Cable to supply and control power without using the Master for the sensor



Specifications	Sensor side	M16 connector (Straight or 90° upward-pointing can be selected)
	Power supply side	Flying lead
	Communication side	RJ45 (Ethernet connection)

Order No.	Product Name	Remarks
02AQL367	2 m Power and Ethernet	1×Open wire end, 1×RJ45 end
02AQL368	5 m Power and Ethernet	1×Open wire end, 1×RJ45 end
02AQL369	10 m Power and Ethernet	1×Open wire end, 1×RJ45 end
02AQL370	15 m Power and Ethernet	1×Open wire end, 1×RJ45 end
02AQL371	20 m Power and Ethernet	1×Open wire end, 1×RJ45 end
02AQL372	25 m Power and Ethernet	1×Open wire end, 1×RJ45 end
02AQL385	2 m Power and Ethernet 90deg	1×Open wire end, 1×RJ45 end, 90° connector
02AQL386	5 m Power and Ethernet 90deg	1×Open wire end, 1×RJ45 end, 90° connector
02AQL387	10 m Power and Ethernet 90deg	1×Open wire end, 1×RJ45 end, 90° connector
02AQL388	15 m Power and Ethernet 90deg	1×Open wire end, 1×RJ45 end, 90° connector
02AQL389	20 m Power and Ethernet 90deg	1×Open wire end, 1×RJ45 end, 90° connector
02AQL390	25 m Power and Ethernet 90deg	1×Open wire end, 1×RJ45 end, 90° connector

I/O cable

Cable to connect the external I/O device to the sensor



Specifications	Sensor side	M16 connector (Straight or 90° upward-pointing can be selected)
	I/O device side	Flying lead
Communication	Encoder input (2-phase square-wave signals Phase A, Phase B, Phase Z), Trigger input, Digital output, RS-485 output	

Order No.	Product Name	Remarks
02AQL361	2 m I/O	Open wire end
02AQL362	5 m I/O	Open wire end
02AQL363	10 m I/O	Open wire end
02AQL364	15 m I/O	Open wire end
02AQL365	20 m I/O	Open wire end
02AQL366	25 m I/O	Open wire end
02AQL379	2 m I/O 90deg	Open wire end, 90° connector
02AQL380	5 m I/O 90deg	Open wire end, 90° connector
02AQL381	10 m I/O 90deg	Open wire end, 90° connector
02AQL382	15 m I/O 90deg	Open wire end, 90° connector
02AQL383	20 m I/O 90deg	Open wire end, 90° connector
02AQL384	25 m I/O 90deg	Open wire end, 90° connector

Note: Sensors cannot be synchronized by the signals input to and output from each sensor through this cable.



Whatever your challenges are, Mitutoyo supports you from start to finish.

Mitutoyo is not only a manufacturer of top quality measuring products but one that also offers qualified support for the lifetime of the equipment, backed up by comprehensive services that ensure your staff can make the very best use of the investment.

Apart from the basics of calibration and repair, Mitutoyo offers product and metrology training, as well as IT support for the sophisticated software used in modern measuring technology. We can also design, build, test and deliver measuring solutions and even, if deemed cost-effective, take your critical measurement challenges in-house on a sub-contract basis.

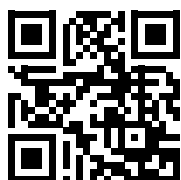

Find additional product literature and our complete catalog here.

Note: Product illustrations are without obligation. Product descriptions, in particular all technical specifications, are only binding when explicitly agreed upon. MITUTOYO and MiCAT are either registered trademarks or trademarks of Mitutoyo Corp. in Japan and/or other countries/regions. Other product, company, and brand names mentioned herein are for identification purposes only and may be the trademarks of their respective holders.



Mitutoyo Europe GmbH

Borsigstraße 8-10
41469 Neuss

Tel. +49 (0) 2137-102-0

info@mitutoyo.eu

www.mitutoyo.eu